

be in motion be in motion

**Three-phase
synchronous motors**

DSD 28-36

Table of contents

Three-Phase Synchronous Motors DSD 28 – 36.....48 – 540 V	2
General technical data	2
Explanations of the motor data	3
Type key	3
Technical data.....	4
Dimension drawings	6
Radial force diagrams.....	8
Brake assignment	9
Main connection cables / preassembled cable with connector	13
Motor characteristics.....	16

Three-Phase Synchronous Motors DSD 28 – 36.....48 – 540 V

General technical data

Version (EN 60034-7):	IM B5 IM V1 IM V3	Horizontal mounting Vertical mounting, shaft end to the bottom Vertical mounting, shaft end to the top
Type of protection (EN 60034-5):	IP 44 IP 65	Surface-cooled, without fan Surface-cooled, without fan
Shaft gland:	IP44	Standard (IP 65 as option with shaft sealing ring)
Connection:		
Main connection:	UVW	8-pin connector
Control connection:		12-pin connector
Brake:		in the main connection
Thermal sensor:		in control connection for resolver in main connection for SinCos encoder
Cooling method:	IC 410	completely enclosed machine surface-cooled no fan
Thermal sensor:		Linear thermal sensor for evaluation in the controller
Temperature rise:	$\Delta\theta = 105 \text{ K}$	Insulation class F acc. to EN 60034
Temperature range:	0....+40 °C	
Storage:	-30 °C...+85 °C	
Bearing life:	$\geq 20,000 \text{ h}$	guide value, calculated bearing life
Flange:		acc. to IEC standard Dimension b1: Tolerance j6
Shaft end:	cylindrical	smooth acc. to DIN 748; (also available with keyway cc. to DIN 6885)Dimension d: Tolerance h6
Holding brake:		Option
Actual speed encoder:		2-pin resolver SinCos encoder (option) other encoders upon request
Converter chopping frequency:		$\geq 4 \text{ kHz}$ (data sheets apply to 8 kHz)
Vibration severity (EN 60034-14):		Level N
Vibration test (EN 60068-2-6):		radial 3 g (10 Hz to 100 Hz) axial 1 g (10 Hz to 100 Hz) (0.5 g with brake)

Explanations of the motor data

M_{0, I_0}	Nominal torque (Nm) with nominal current (A) at speed $\leq 1 \text{ min}^{-1}$ without time limit, I_0 is the r.m.s. value
$M_{0, \max}, I_{0, \max}$	Maximum torque (Nm) with maximum current (A) at speed = 0, $I_{0, \max}$ is the r.m.s. value
P_N	Nominal power (W) with nominal speed n_N in continuous operation (S1) $T_A = 40^\circ\text{C}$ installation up to 1000 m a.m.s.l.
M_N, I_N	Nominal torque (Nm) with nominal current (A) at nominal speed n_N in continuous operation (S1); $T_A = 40^\circ\text{C}$
n_N	Nominal speed (min^{-1})
k_{TN}	Torque constant: M_N/I_N
f_N	Nominal frequency (Hz)
J	Rotor inertia incl. resolver without holding brake (kgcm^2)
M	Weight in kg

The specified ratings and torques at nominal speed are achieved in converter operation with a chopping frequency of $\geq 4 \text{ kHz}$ in the power unit. A chopping frequency of $> 6 \text{ kHz}$ is recommended.

Type key

DSD	G	036	L	44	U	30	54			
								DC link voltage:	54	540 V
									31	310 V
									06	60 V
									X	Special
								Nominal speed:	45	4,500 min^{-1}
									60	6,000 min^{-1}
									X	Special
								Cooling:	U	Without fan
								Type of protection:	44	IP 44
									65	IP 65
								Length:	S	
									M	
									L	
								Size:	022	
									028	
									036	
								Holding brake:	without	
									with	G
								Motor type:	DSD	Three-phase synchronous dynamic

Technical data

Mains voltage 1 AC 230 V

for pulse converters with uncontrolled supply, 8 kHz clocked and commutation acc. to the sinusoidal current principle

Nom. speed	Motor type	Stand-still torque ¹⁾	Stand-still current ¹⁾	Max. stand-still torque	Max. stand-still current	Nom. power ¹⁾	Nom. torque ¹⁾	Nom. current ¹⁾	Torque constant	Nom. frequency	Rotor inertia (motor)	Weight
n_N min ⁻¹		M_O Nm	I_O A	$M_{O,max}$ Nm	$I_{O,max}$ A	P_N kW	M_N Nm	I_N A	k_{TN} Nm/A	f_N Hz	J Kgcm ²	m kg
4500	DSD028S65U45-3	0.7	1.55	2.0	6.1	0.28	0.60	1.40	0.43	300	0.13	1.3
	DSD028M65U45-3	1.2	2.6	3.9	11.9	0.47	1.0	2.3	0.43	300	0.2	1.8
6000	DSD028S65U60-3	0.7	1.9	2.0	7.5	0.35	0.55	1.65	0.34	400	0.13	1.3
	DSD028M65U60-3	1.2	3.0	3.9	13.7	0.57	0.9	2.4	0.38	400	0.2	1.8
4000	DSD036S65U40-3	1.20	2.4	2.80	7.9	0.44	1.05	2.2	0.48	267	0.18	2.1
	DSD036M65U40-3	2.0	3.6	5.7	15.1	0.67	1.60	2.9	0.55	267	0.3	2.9
4500	DSD036L65U45-3	2.8	5.0	8.4	22.0	0.85	1.8	3.45	0.53	300	0.42	3.7
6000	DSD036S65U60-3	1.20	3.55	2.80	12.0	0.57	0.90	2.70	0.33	400	0.18	2.1
	DSD036M65U60-3	2.0	5.0	5.7	21.0	0.82	1.30	3.35	0.39	400	0.3	2.9
	DSD036L65U60-3	2.8	6.15	8.4	27.2	0.9	1.45	3.45	0.42	400	0.42	3.7

1) Winding overheat DT < 105 K; direct flange connection (mounting plate 250 mm x 250 mm)

Mains voltage 3 AC 400 V

for pulse converters with uncontrolled supply, 8 kHz clocked and commutation acc. to the sinusoidal current principle

Nom. speed	Motor type	Stand-still torque ¹⁾	Stand-still current ¹⁾	Max. stand-still torque	Max. stand-still current	Nom. power ¹⁾	Nom. torque ¹⁾	Nom. current ¹⁾	Torque constant	Nom. frequency	Rotor inertia (motor)	Weight
n_N min ⁻¹		M_O Nm	I_O A	$M_{O,max}$ Nm	$I_{O,max}$ A	P_N kW	M_N Nm	I_N A	k_{TN} Nm/A	f_N Hz	J Kgcm ²	M kg
6000	DSD028S65U60-5	0.7	1.0	2.0	4.0	0.35	0.55	0.85	0.65	400	0.13	1.3
6000	DSD028M65U60-5	1.2	1.7	3.9	7.8	0.57	0.9	1.35	0.67	400	0.2	1.8
4000	DSD036S65U40-5	1.20	1.45	2.80	4.7	0.44	1.05	1.35	0.78	267	0.18	2.1
4500	DSD036M65U45-5	2.0	2.55	5.7	10.7	0.71	1.5	1.95	0.77	300	0.3	2.9
	DSD036L65U45-5	2.8	3.45	8.4	15.3	0.85	1.8	2.30	0.78	300	0.42	3.7
6000	DSD036S65U60-5	1.20	2.05	2.80	7.0	0.57	0.90	1.50	0.60	400	0.18	2.1
	DSD036M65U60-5	2.0	2.95	5.7	12.0	0.82	1.30	2.00	0.65	400	0.3	2.9
	DSD036L65U60-5	2.8	3.85	8.4	17.0	0.9	1.45	2.15	0.67	400	0.42	3.7

1) Winding overheat DT < 105 K; direct flange connection (mounting plate 250 mm x 250 mm)

Dimension drawings

DSD 28

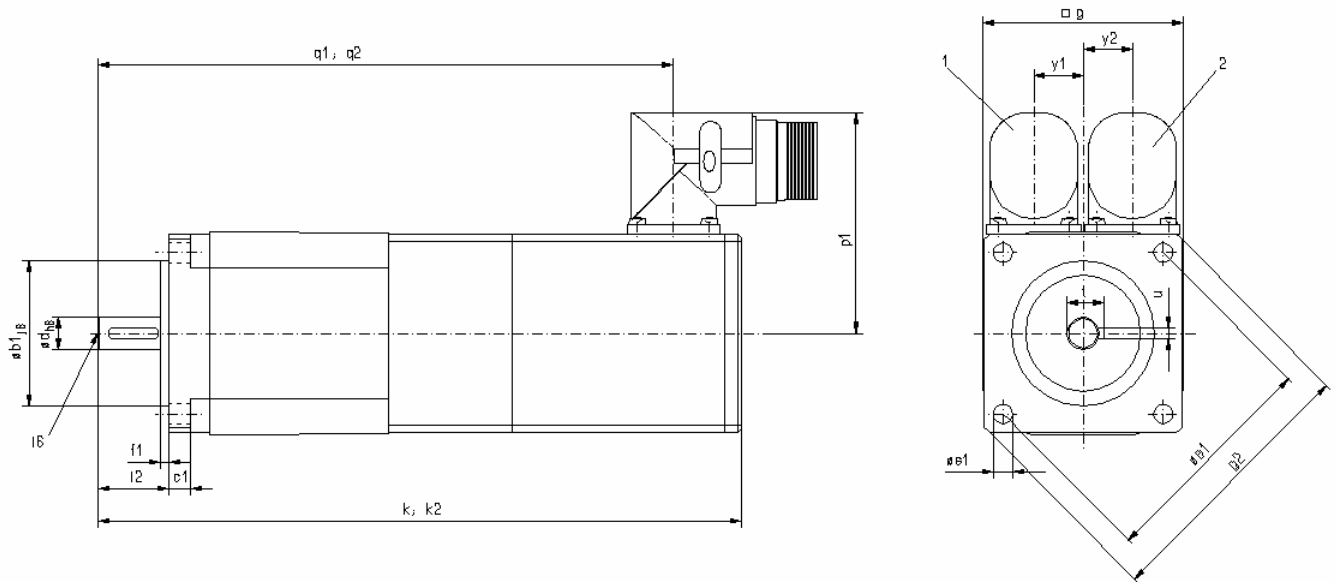

Type	Flange							Shaft			Motor											Brake			
	a1	b1	c1	e1	f1	i2	s1	d	t	u	g2	g	g1	k	m1	p1	q	q1	y	y1	y2	s2	s3	k2	q2
28S	-	40	6	63	2.5	20	5.4	9	10.2	3	75	56	-	120	-	61	-	102	-	13.7	13.7	-	-	160	141
28M														150				132						190	171

DSD 36

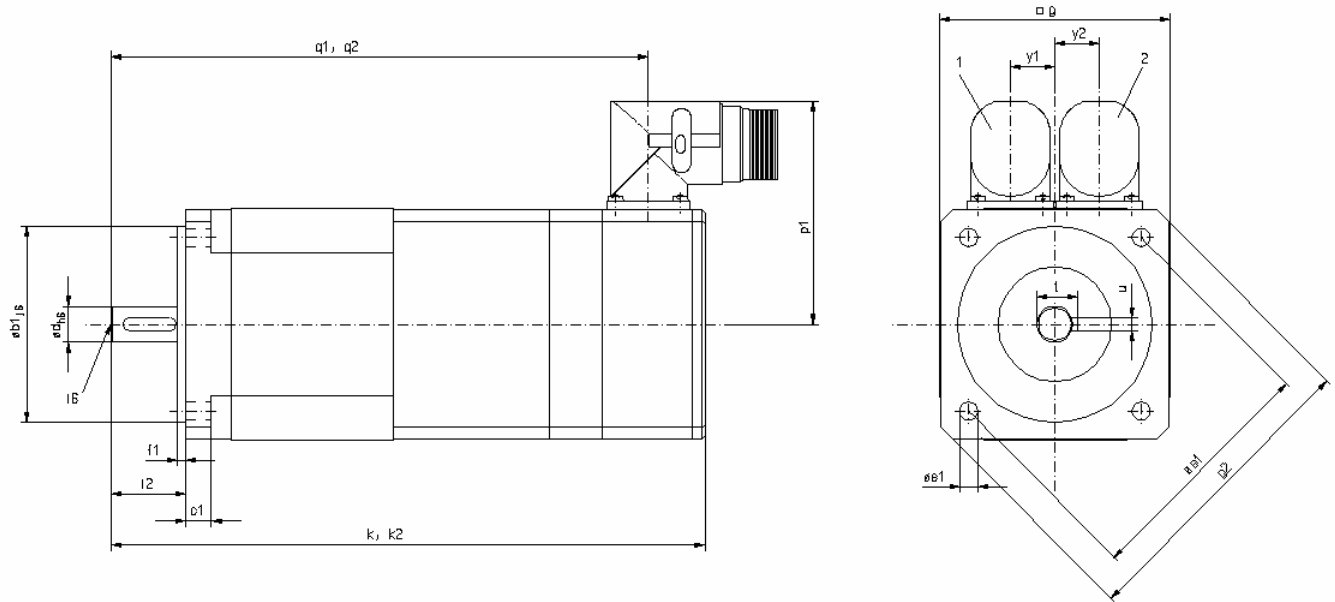

Type	Flange							Shaft		Motor													Brake			
	a1	b1	c1	e1	f1	i2	s1	d	t	u	g2	g	g1	k	m1	p1	q	q1	y	y1	y2	s	s2	s3	k2	q2
36S	-	60	8	75	2.5	23	5.5	11	12.5	4	94	71	-	141	-	69	-	123.5	-	13.7	13.7	-	-	-	183	165.5
36M														171				153.5							220	202.5
36L														201				183.5							250	232.5

Radial force diagrams

Permissible radial force F_R at the shaft end

All bearings are dimensioned for a service life of approx. 20,000 operating hours; the loads specified in the following must not be exceeded. The specified permissible radial forces F_R are valid only for horizontal mounting of the motor without additional axial forces.

Axial load of the motor shaft

When mounting clutches, pulleys, etc. onto the motor shaft, axial forces must not occur!
Therefore use the internal thread of the shaft end as assembly aid.

Force acting on the end of the shaft end (for force acting on the middle of the shaft end $F_r \times 1.1$)
Bearing life 20,000 h; shaft end without keyway.

Diagrams

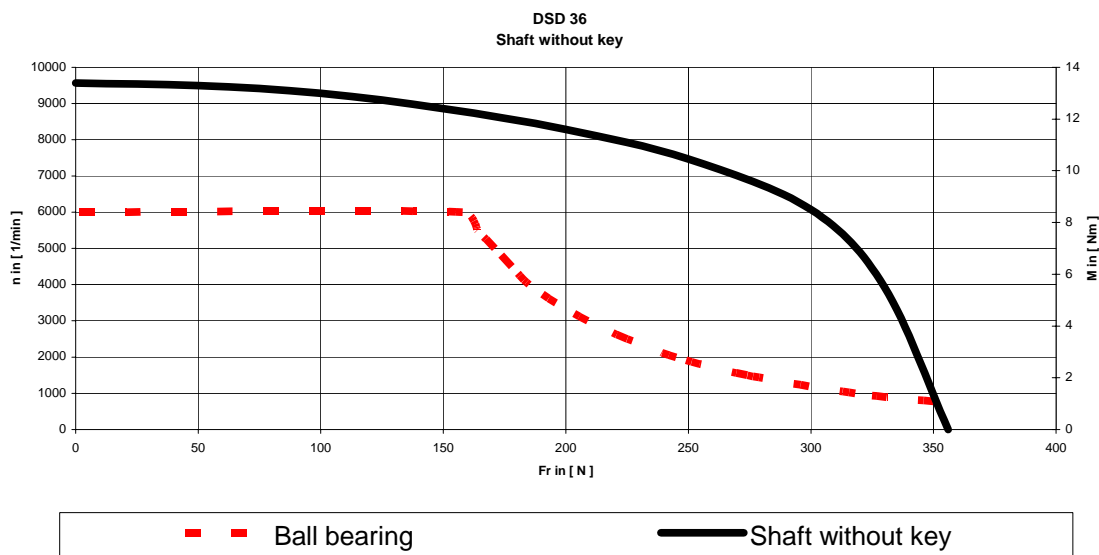
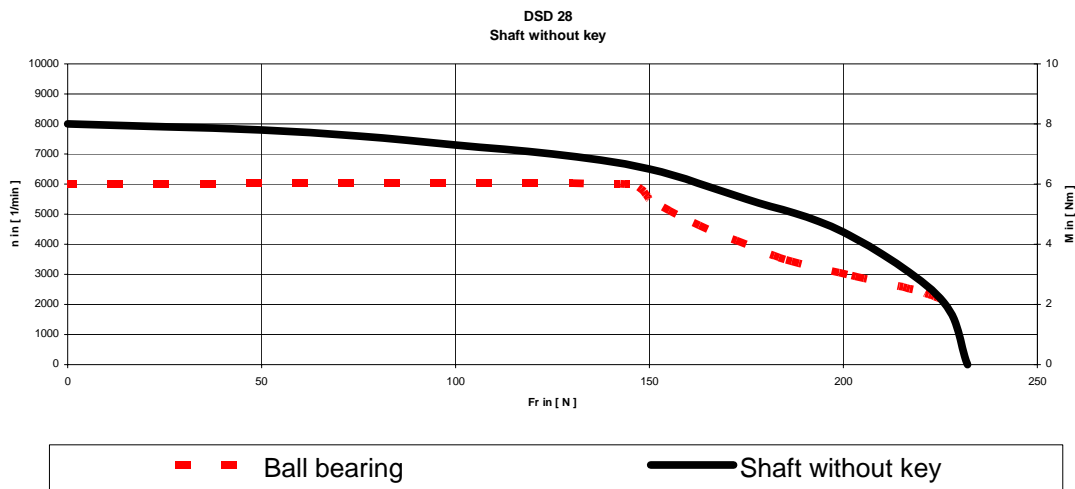

Explanation of the diagram

The radial force F_r of the application is used to determine the possible maximum speed of the bearing in the "Ball bearing" characteristic.

Radial force 300 N => maximum speed 1150 min⁻¹

The maximum transmittable torque results from the "Shaft" characteristic.

Radial force 300 N => maximum transmittable torque 8.5 Nm.

Brake assignment

The motors are optionally equipped with a holding brake. The brake uses the normally-on principle, i.e. the brake engages if the operating voltage is switched off or fails. The brakes are supplied for a switching voltage of 24 VDC ± 10%.

The motors are available with the following holding brakes:

Motor type	DSD 28 S	DSD 28 M	DSD 36 S	DSD 36 M	DSD 36 L
Minimum holding torque at 100 °C (Nm)	2.5	2.5	2.5	4.5	4.5
Max. perm. friction work per braking operation (J)	250	250	250	580	580
Connected loads (+7% -7% smoothed)	24 V = 8 W	24 V = 8 W	24 V = 8 W	24 V = 9 W	24 V = 9 W
Inertia (kgcm ²)	0.068	0.068	0.068	0.18	0.18
Maximum speed (min)	10000	10000	10000	10000	10000
Switch-on to brake released (ms)	11	11	11	18,5	18,5
Off (ms)	37	37	37	50	50
Weight (kg)	0,17	0,17	0,17	0,35	0,35

None of the brakes are fail-safe brakes so that the torque may be reduced by interference factors beyond control. In accordance with the case of application, observe the relevant accident prevention guidelines as well as the basic safety and health requirements of Appendix I of the Machinery Directive and the harmonized European Standards.

In the event of emergency stop or voltage failure, approx. 2,500 braking operations can be carried out without causing the holding brake to overheat (Condition: maximum external inertia = motor inertia and n_{max} . type-related).

Motor connection

Power

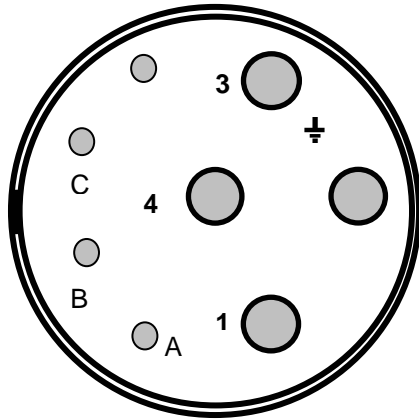

Pin	Signal	Color/ Labelling
1	Phase U	U
2	PE	green/yellow
3	Phase V	VV
4	Phase W	WWW
A	Breake+	red
B	Breake-	black
C	KTY +	white
D	KTY -	yellow

Encoder

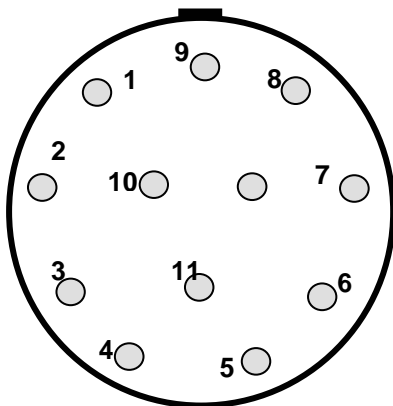

Pin	Resolver Signals	SinCos encoder SRS50/SRM50 SKS36/SKM36 Signals
1	Cos -	Ref Cos
2	-	Data+(+ RS485)
3	-	-
4	-	-
5	Sin -	+ Sin
6	Sin +	Ref Sin
7	TM -	Data-(- RS485)
8	Cos +	Cos
9	TM +	-
10	Ref +	Gnd
11	-	-
12	Ref -	+ U

Resolver data

Pole pair number	1
Ratio	0,5
Frequency	5 kHz
Nominal input resistance	4 V
Active input power for no-load operation	112 mW
Current consumption for no-load operation	40 mA
Max. output voltage for no-load operation	2 V _{eff}
Voltage constant	-
Rotor resistance	40 Ω ±10%
Stator resistance	102 Ω ±10%
Rotor impedance for no-load operation	70 + j74 Ω ± 15%
Rotor impedance for short-circuit	62 + j66 Ω ± 15%
Stator impedance for no-load operation with max. coupling	108 + j206 Ω ± 15%
Stator impedance for short-circuit with max. coupling	97 + j183 Ω ± 15%
Phase shift	8°
Zero voltage	15 mV
Phase error referenced to zero position	10'

Data for SINCOS SRS/SRM 50, SKS/SKM 36 (Sick/Stegmann)

	SRS 50	SRM 50	SKS 36	SKM 36
Number of sine, cosine periods per revolution	1024	1024	128	128
Number of increments per revolution	32768	32768	4096	4096
Number of absolute resolved revolutions	1	4096	1	4096
Code type for the absolute value	Binary	Binary	Binary	Binary
Output frequency of sine, cosine signals (kHz)	0...200	0...200	0...65	0...65
Error limits when evaluating 1024/128 signals, integral non-linearity (arc seconds)	+/-45	+/-45	+/-1,3	+/-1,3
Non-linearity within a sine, cosine period; differential non-linearity (arc seconds)	+/- 7	+/- 7	+/-0,6	+/-0,6
Working speed up to which the absolute position can be formed (1/min)	6000	6000	6000	6000
Maximum operating speed (1/min)	12000	12000	12000	12000
Output signals; 2x90° offset sinusoidal signals (V _{pp})	1	1	1	1
Output signal	serial RS 485, asynchronous, half duplex	serial RS 485, asynchronous, half duplex	serial RS 485, asynchronous, half duplex	serial RS 485, asynchronous, half duplex
Operating voltage range (V)	7...12	7...12	7...12	7...12
Operating current without load (mA)	80	80	60	60

Motor cables**General**

The motor cables are highly flexible trailing cables with overall shielding. They comply with the regulations VDE, UL and CSA.

The control cables are integrated as star quads. When the sincos encoder is used, the brake triggering and the connection of the thermal sensor are brought out via the main connector.

The cables are particularly suitable for the optimum use of cable racks thanks to their low cross-section, low weight and non-impeding surface. They can thus be efficiently used in trailing chains.

The overall shielding with an optical coverage of more than 85% makes it an EMC uncritical cable.

The connector size is designed in accordance with the motor's standstill current I_0 .

Technical data**Technical description**

- Sheath resistance against media such as coolants, machine and gearbox oils
- Abrasion resistance because of a special surface in cable racks and trailing chains
- High-flexible, trailing cable
- Sheath surface not blocking, satin-finish
- Shield made of tinned copper braid with optical coverage of $\geq 85\%$
- Core insulation made of TPE or polyester, sheath material PUR halogene-free
- Cable FCF-free and silicone-free
- Behaviour in case of fire: fire-inhibiting, halogene-free
- Cable color in RAL 1028, melon yellow
- Labelling with Baumüller sign, VDE, UL and CSA sign
- Minimum bending radius for flexible use $12 \times D$

Nominal voltage

U_o/U 600/1000 V (power cores)

U 24 V DC (control cores)

Core lettering

Power cores U, VV, WWW

Colored control cable pairs as star-quads in red, white, black, yellow

Assignment of pairs red – black (brake),

white – yellow (temperature)

Cable data

Cable cross-section	Nominal current [A] ¹⁾	Cable diameter [mm]
$4 \times 1.5 \text{ mm}^2$ $4 \times 0.75 \text{ mm}^2$	15	11.7 – 12.3

- 1) Current carrying capacity acc. to table 5 laying type C or E
(VDE 0113 / EN 60 204 Part 1 issue 1997)
Ambient temperature 40°C

Cable–connector assignment

Cable cross-sections	Nominal current [A]	Male connector 540 V Size
4×1.5 mm ² 4×0.75 mm ²	15	1
4×2.5 mm ² 4×0.75 mm ²	21	1.5
4×4 mm ² 4×0.75 mm ²	28	1.5
4×6 mm ² 4×0.75 mm ²	36	1.5
4×10 mm ² 4×0.75 mm ²	50	1.5

The connectors must be designed with respect to the I_0 motor current. For the laying of the cables, the current carrying capacity acc. to table 5 laying type C or E (VDE 0113 / EN 60 204 Part 1 issue 1997) and an ambient temperature of 40°C must be considered.

Cables of 2.5 mm² can be laid up to 100 m without additional filters, when larger cross-sections are used, up to 40 m are permissible. The terminal voltage at the motor must be < 1 kV. When longer cables are used, filters must be installed between converter and motor.

Application notes

Operating temperature

The cables can be operated within a temperature range from –20°C to +80°C.

Cable laying at the motor

The cables must not touch the motor surface.

Smallest permissible bending radii

12 times outer cable diameter

Smaller bending radii are possible with reduced service life.

Main connection cables / preassembled cable with connector

Nominal current: 15 A

Cable 4 x 1.5 mm² + 4 x 0.75 mm²
with connector size 1

Length in m	Article number
5	324781
7	324782
10	324783
15	324784
20	324785
25	324786
30	324787
35	324788
40	324789
50	324790
75	324791
100	324792

Encoder cables

General

A fully preassembled encoder cable is used for all encoder systems. Motor connection is via a 12-pin round signal connector and converter connection via a 15-pin sub-D plug. The encoder cables are available as 'trailing' and 'non-trailing' cables.

The trailing cable is suitable for use in trailing chains, for example. As opposed to the 'non-trailing' cable, the cable sheath consists of tougher PUR for use in environments with acids and bases (coolants) instead of PVC. Up to a length of 10 m, the cables are available in 1 m sections (1 m, 2 m, 10 m). From a cable length of 10 m, the sections come in 5 m intervals (10 m, 15 m, ...).

In the case of servo motors, the resolver encoder system links the temperature sensor with the converter via the encoder cable.

Technical data

1. Technical description – non-trailing

- LiYCY, 5x (2 x 0.14 mm²) + 2 x 0.5 mm² copper lead, twisted pair
- PVC sheath, grey
- 1st end: 12-pin signal circular connector with 12 female contacts
- 2nd end: 15-pin D-Sub connector with male contacts and locking screws 4-4OUNC
- Baumüller labelling, black
- Outer diameter 9.0 mm (+/-3 mm)
- Bending radius: $r \geq 60$ mm (fixed installation), $r \geq 135$ mm (flexible use)
- Nominal voltage: 250 V_{AC}

2. Technical description – trailing

- Li12YC11Y, 5x (2x0.14 mm²) + 2 x 0.5 mm² copper lead, twisted pair
- PU sheath, black
- 1st end: 12-pin signal circular connector with 12 female contacts
- 2nd end: 15-pin D-Sub connector with male contacts and locking screws 4-4OUNC
- Baumüller labelling, white
- Outer diameter 9.0 mm (+/-3 mm)
- Bending radius: $r \geq 70$ mm (fixed installation), $r \geq 100$ mm (flexible use)
- Nominal voltage: 300 V_{AC}

Application notes

- Operating temperature

	trailing	non-trailing
Limit temperature	at the surface	at the surface
no / few movements	- 40 °C to + 80 °C	- 30 °C to + 80 °C
continuous movements	- 30 °C to +80 °C	-5 °C to + 70 °C

- Cable laying at the motor

The cables must not touch the motor surface.

Ordering data

Encoder cables / preassembled cables with connector

Encoder cable

non-trailing, preassembled

Cable 5 x (2 x 0.14 mm²) + 2 x 0.5 mm² with connector

Length in m	Article number
1	243601
2	211338
3	219333
4	231166
5	209879
6	220197
7	216455
8	220429
10	210052
15	215716
20	218568
25	218569
30	217094
35	216444
40	217095
45	217567
50	217568
55	217569
60	217570
70	232088

trailing, preassembled

Cable 5 x (2 x 0.14 mm²) + 2 x 0.5 mm² with connector

Length in m	Article number
3	246658
4	243379
5	239540
6	242954
8	239541
10	239542
15	239543
20	239544
25	239545
30	239546
35	239547
40	240520
45	240521
50	240522
55	244033
60	245484

Encoder connector	Article number
Encoder connector	201833

Commissioning and maintenance instructions

Please contact us for our commissioning and maintenance instructions for motor commissioning.

Motor characteristics

DSD 28 S

Nominal speed n_N 4500 min⁻¹

DC link voltage $V_{DCL} = 310$ V - 1 X 230 V AC

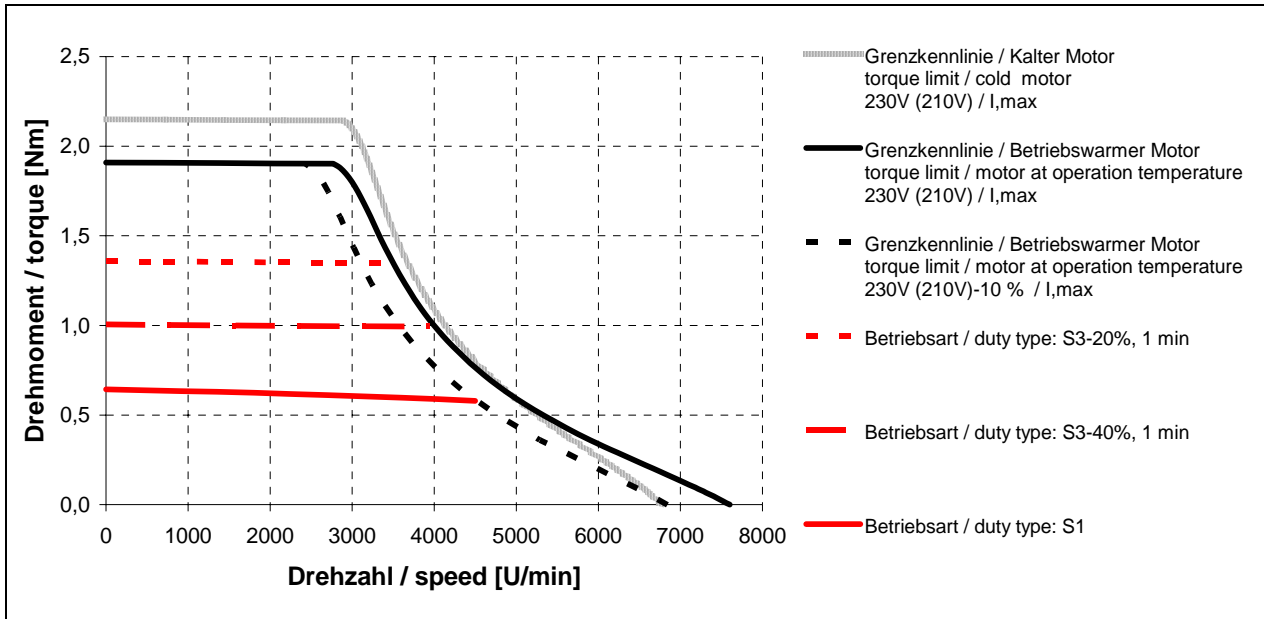

DSD 28 S

Nominal speed n_N 6000 min⁻¹

DC link voltage $V_{DCL} = 310$ V - 1 X 230 V AC

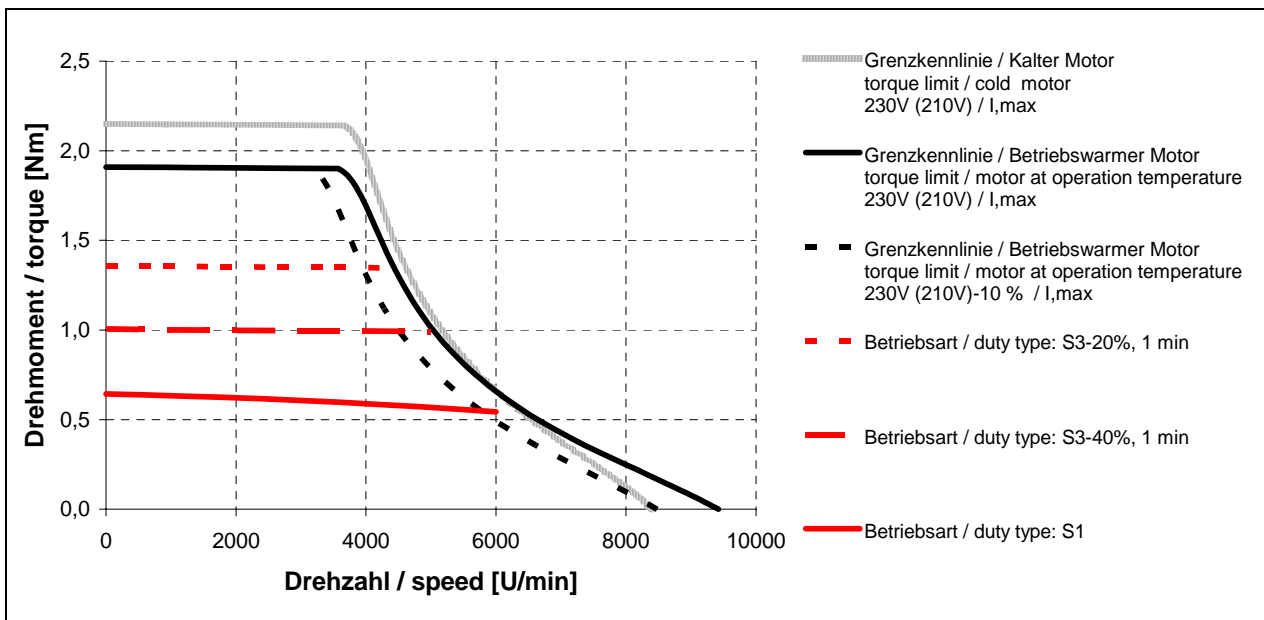

DSD 28 S

Nominal speed n_N 6000 min⁻¹

DC link voltage $V_{DCL} = 540$ V – 3 X 400 V AC

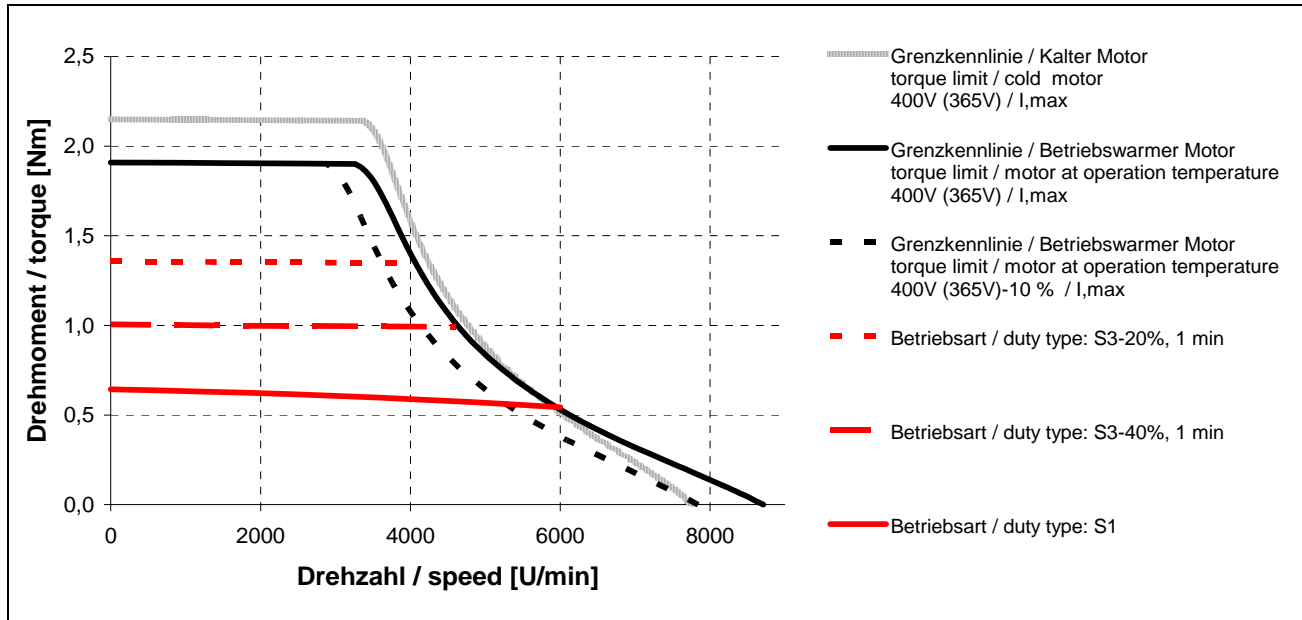

DSD 28 M

Nominal speed n_N 4500 min⁻¹

DC link voltage $V_{DCL} = 310$ V - 1 X 230 V AC

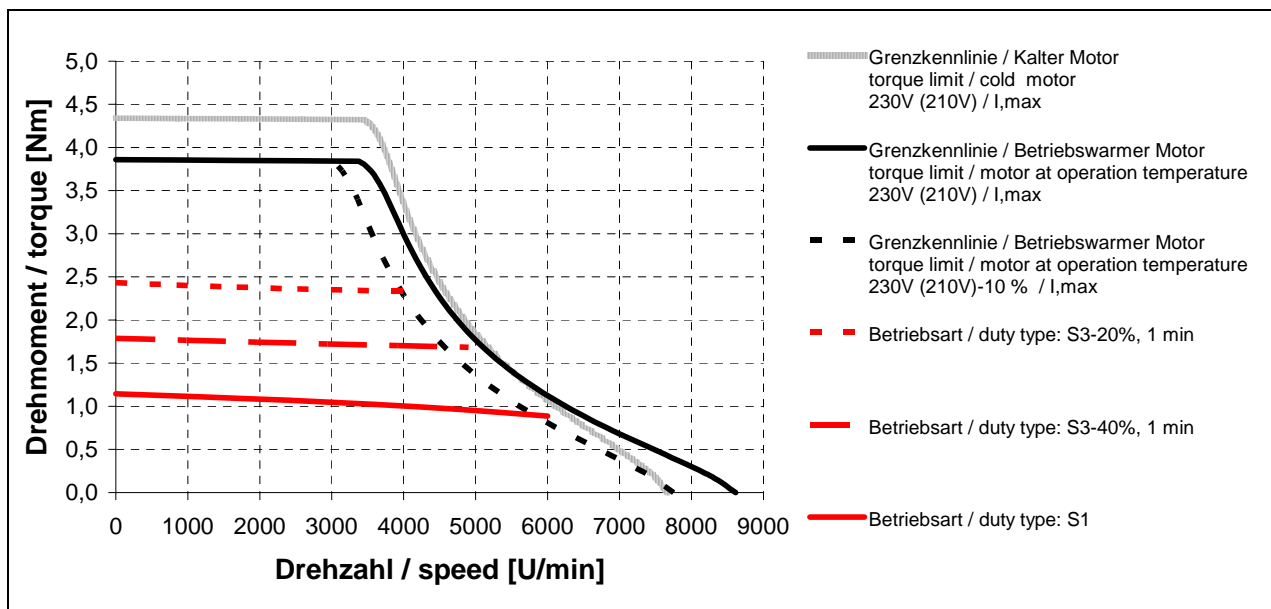

Three-Phase Synchronous Motors DSD 28-36 / 48-540 V

DSD 28 M

Nominal speed n_N 6000 min⁻¹

DC link voltage $V_{DCL} = 310$ V - 1 X 230 V AC

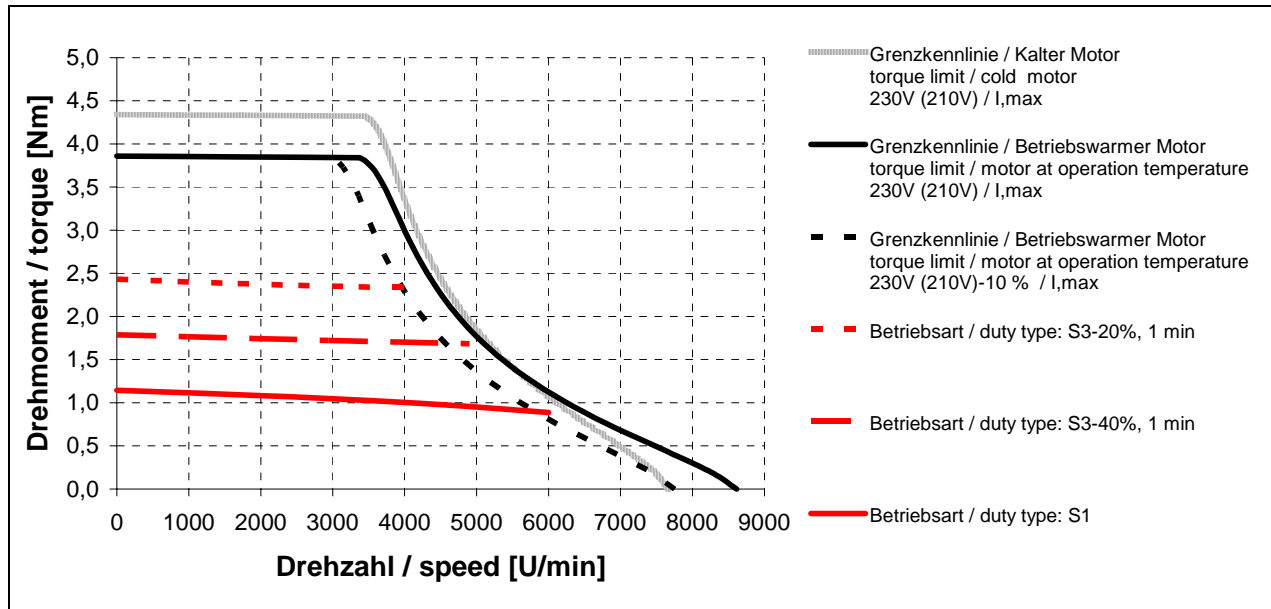

DSD 28 M

Nominal speed n_N 6000 min⁻¹

DC link voltage $V_{DCL} = 540$ V - 3 X 400 V AC

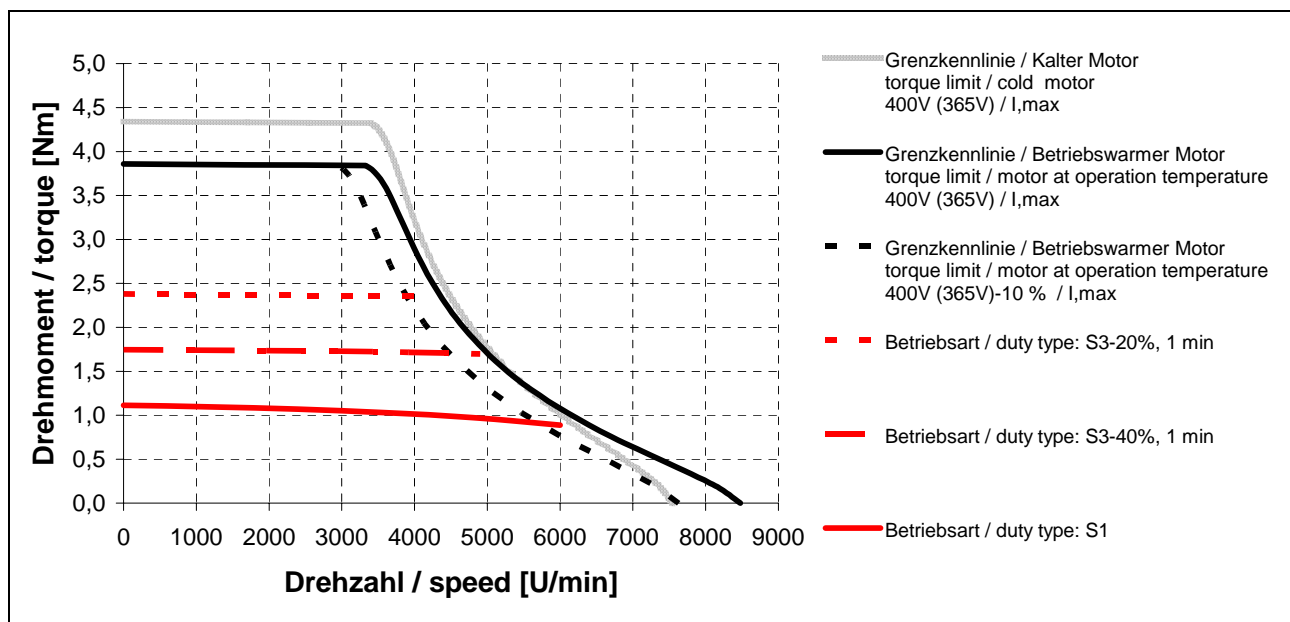

DSD 36 S

Nominal speed n_N 4000 min⁻¹

DC link voltage $V_{DCL} = 310$ V - 1 X 230 V AC

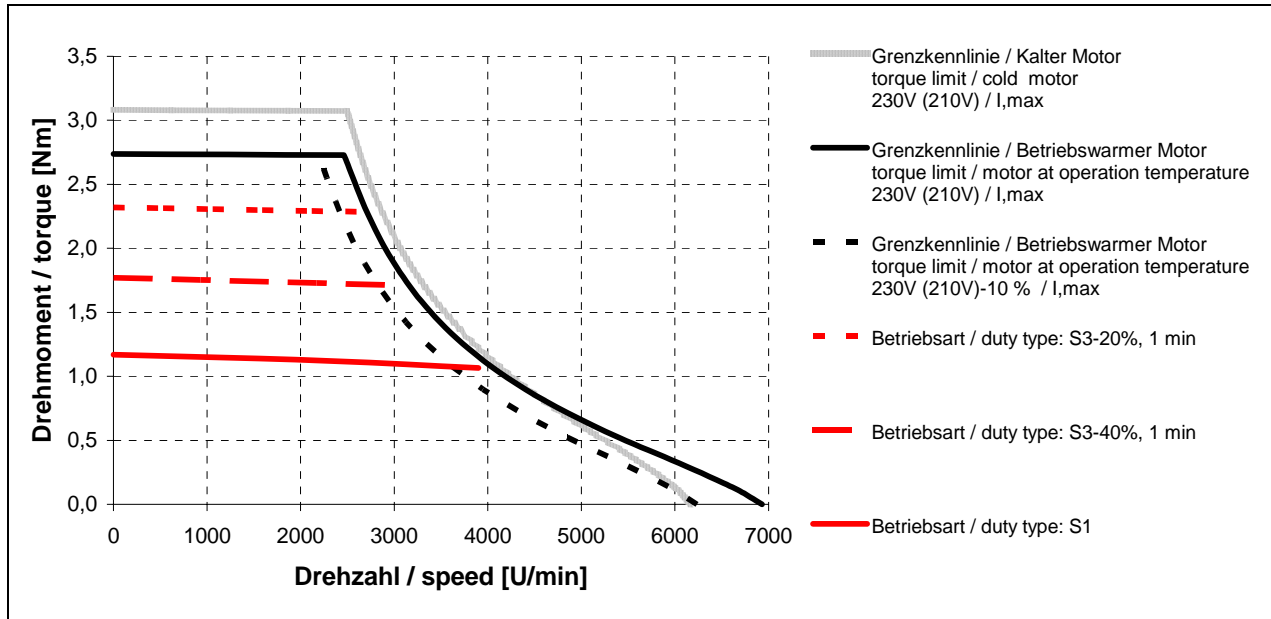

DSD 36 S

Nominal speed n_N 6000 min⁻¹

DC link voltage $V_{DCL} = 310$ V - 1 X 230 V AC

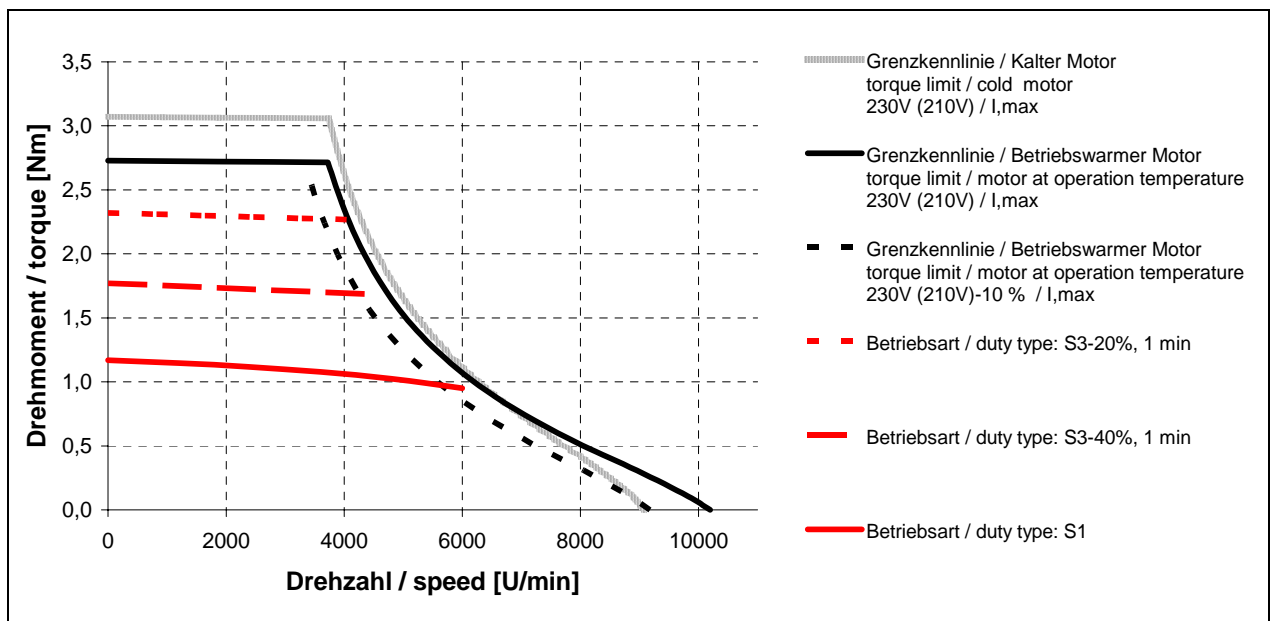

DSD 36 S

Nominal speed n_N 4000 min⁻¹

DC link voltage $V_{DCL} = 540$ V - 3 X 400 V AC

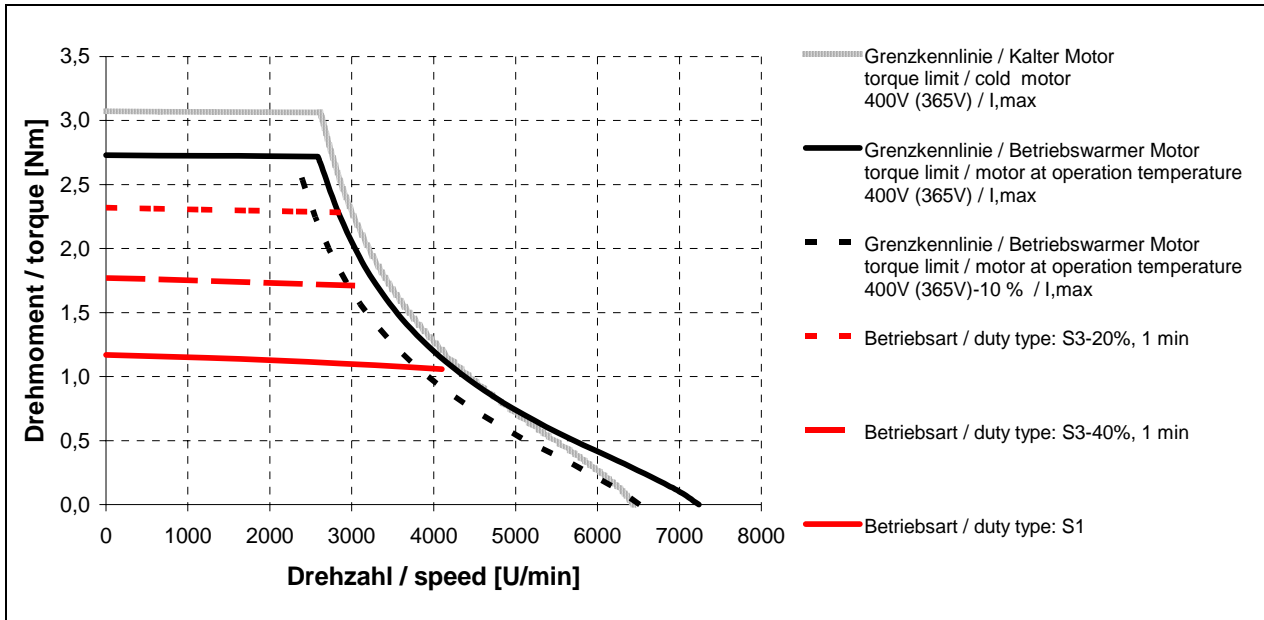

DSD 36 S

Nominal speed n_N 6000 min⁻¹

DC link voltage $V_{DCL} = 540$ V - 3 X 400 V AC

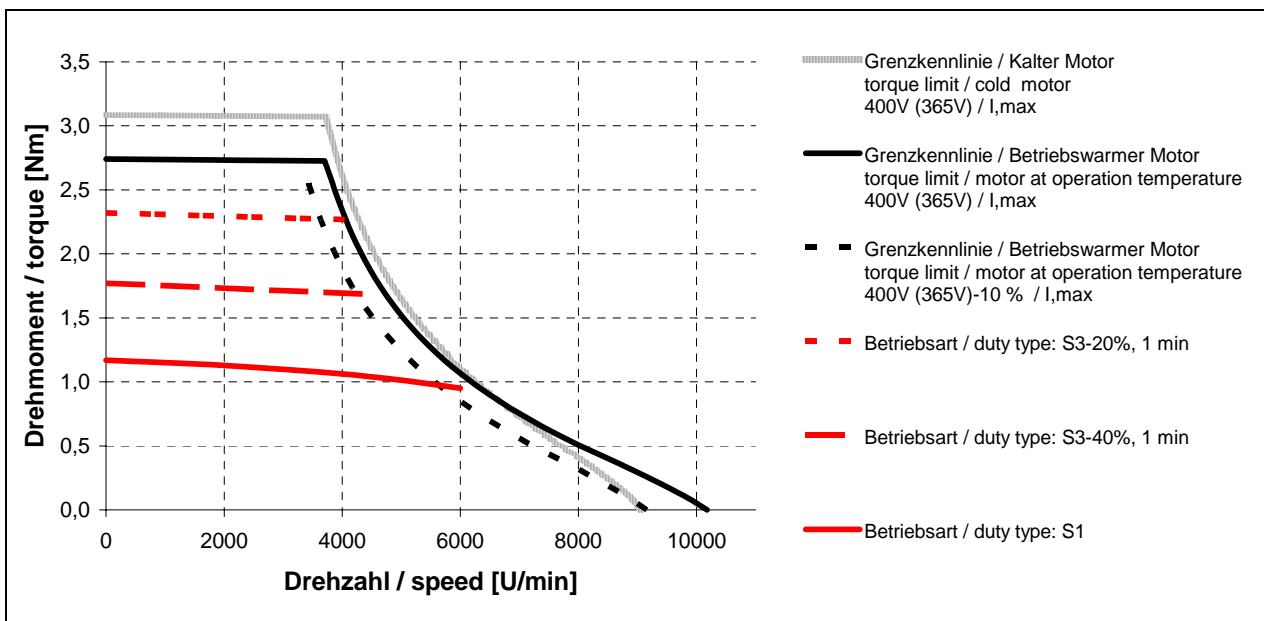

DSD 36 M

Nominal speed n_N 4000 min⁻¹

DC link voltage $V_{DCL} = 310$ V - 1 X 230 V AC

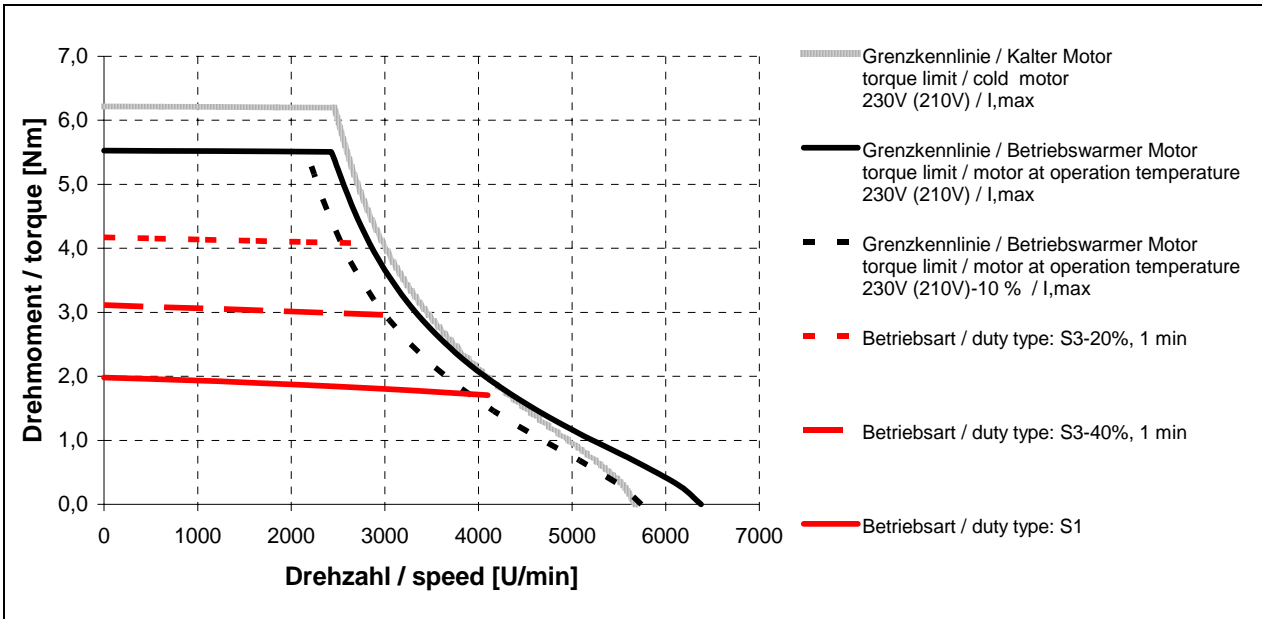

DSD 36 M

Nominal speed n_N 6000 min⁻¹

DC link voltage $V_{DCL} = 310$ V - 1 X 230 V AC

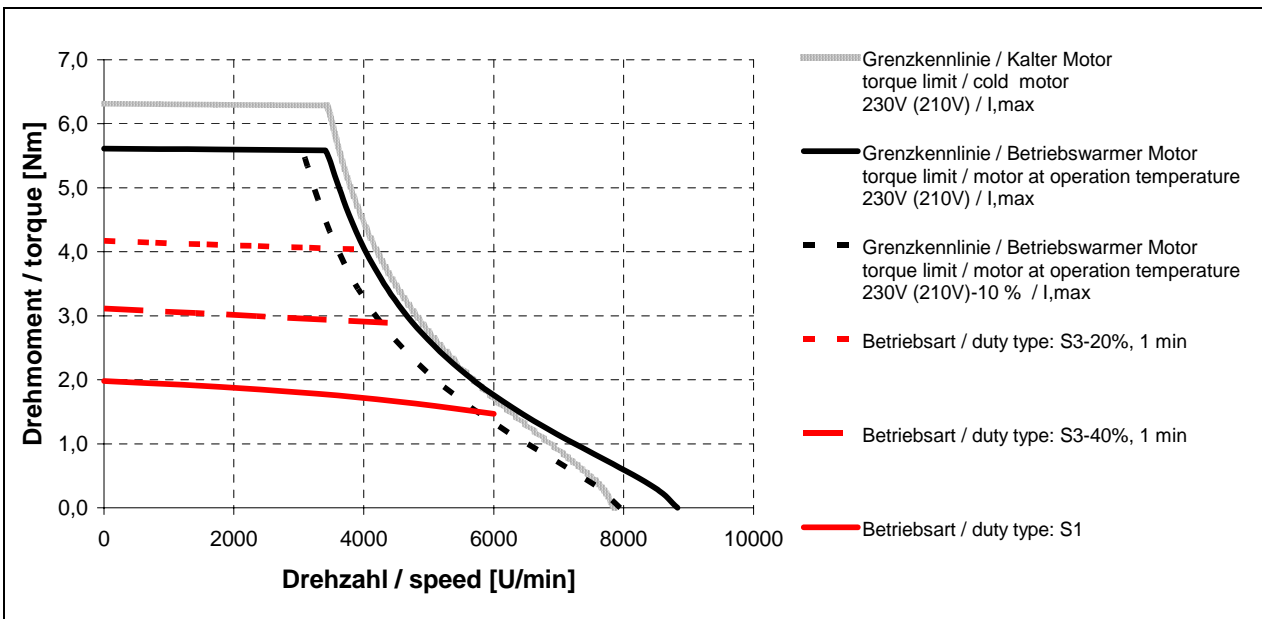

DSD 36 M

Nominal speed n_N 4500 min⁻¹

DC link voltage $V_{DCL} = 540$ V - 3 X 400 V AC

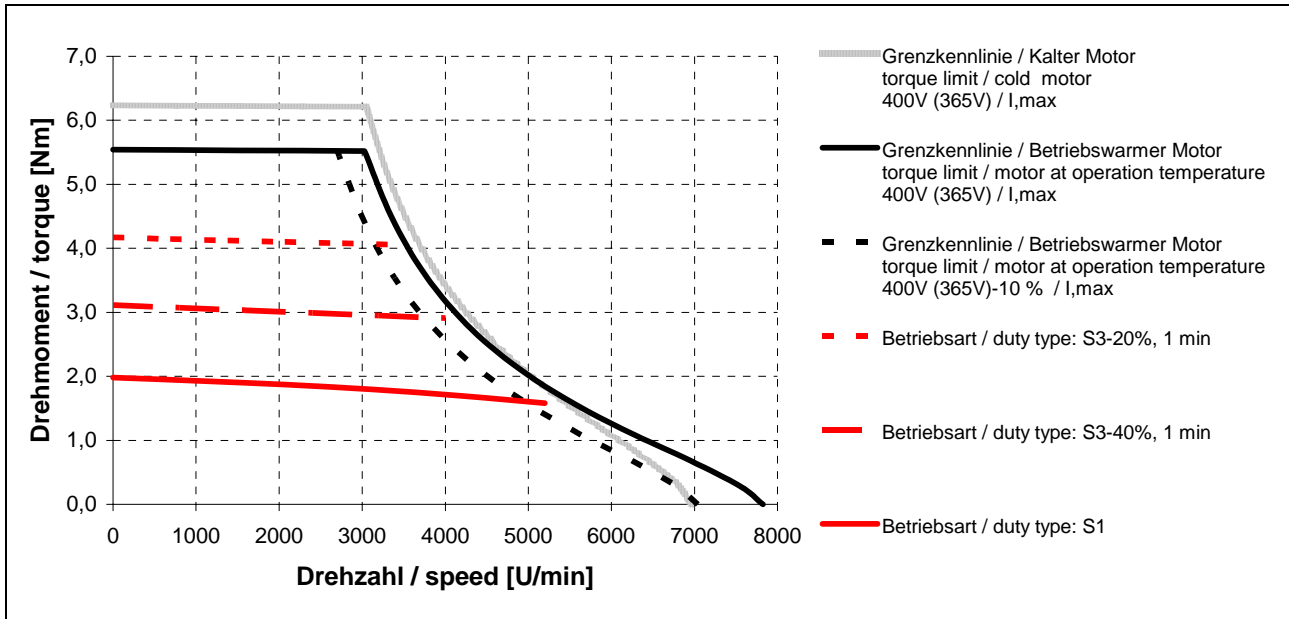

DSD 36 M

Nominal speed n_N 6000 min⁻¹

DC link voltage $V_{DCL} = 540$ V - 3 X 400 V AC

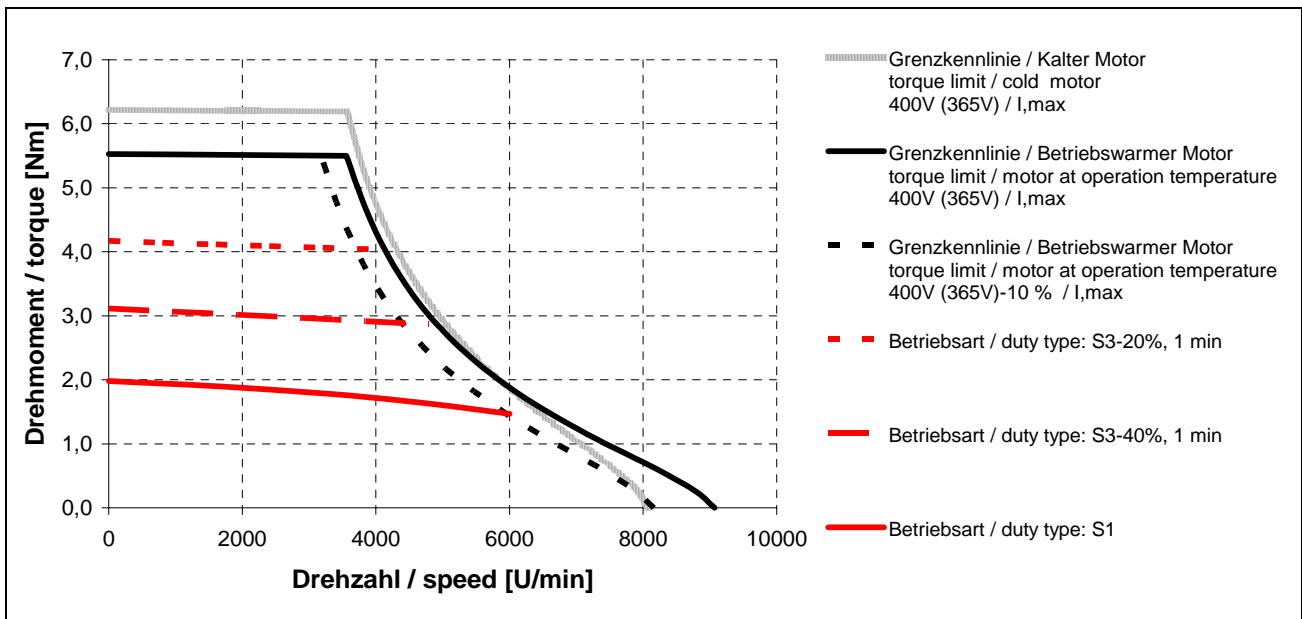

DSD 36 L

Nominal speed n_N 4500 min⁻¹

DC link voltage $V_{DCL} = 310$ V - 1 X 230 V AC

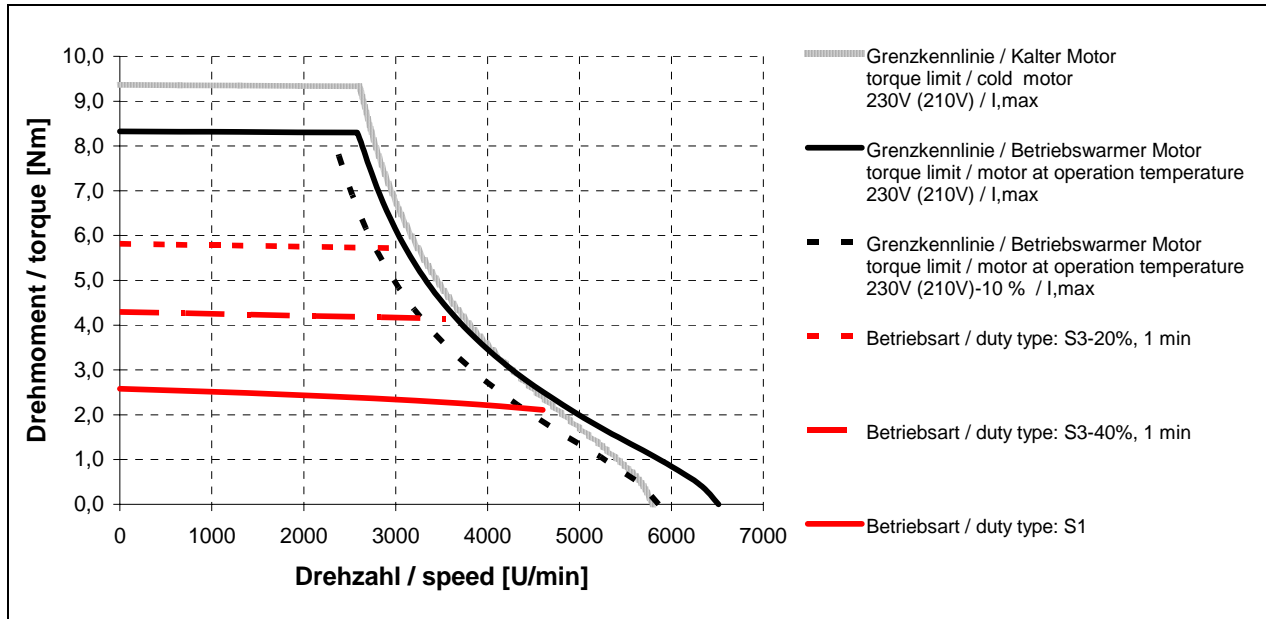

DSD 36 L

Nominal speed n_N 6000 min⁻¹

DC link voltage $V_{DCL} = 310$ V - 1 X 230 V AC

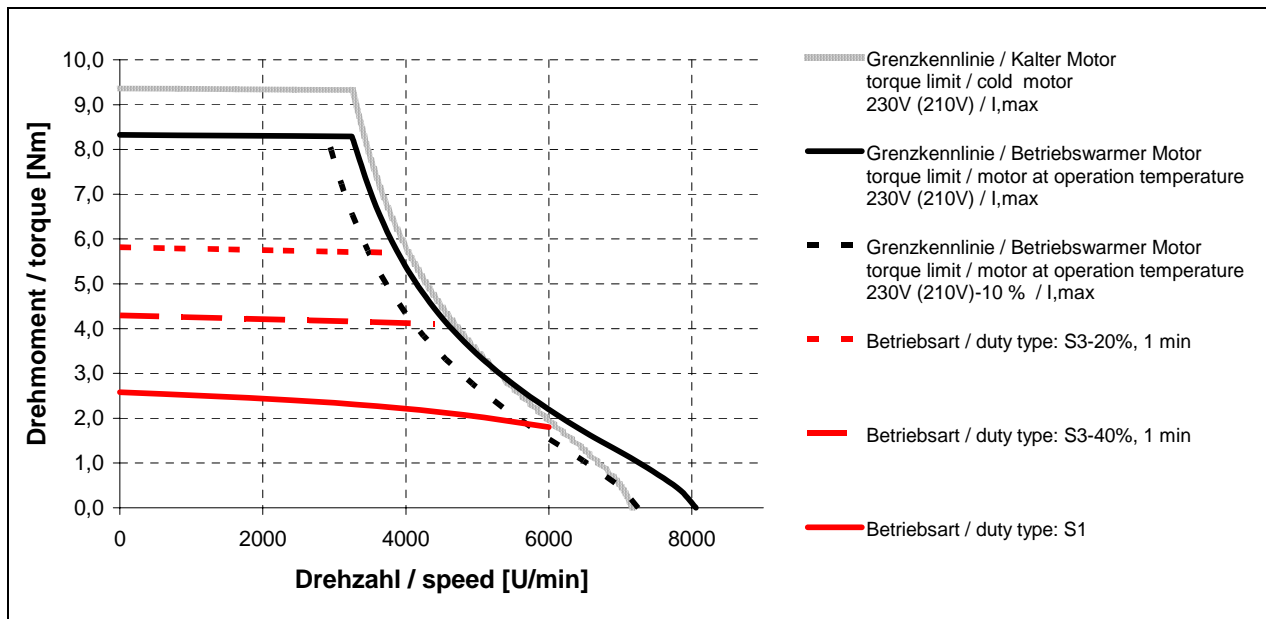

DSD 36 L

Nominal speed n_N 4500 min⁻¹

DC link voltage $V_{DCL} = 540$ V - 3 X 400 V AC

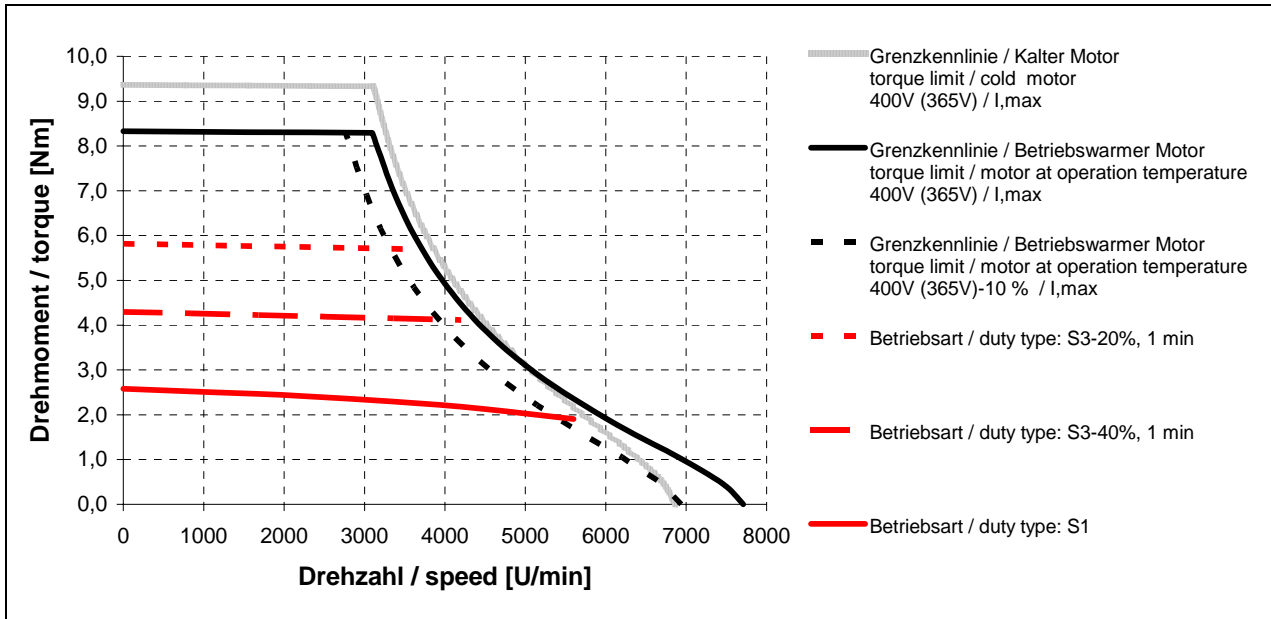

DSD 36 L

Nominal speed n_N 6000 min⁻¹

DC link voltage $V_{DCL} = 540$ V - 3 X 400 V AC

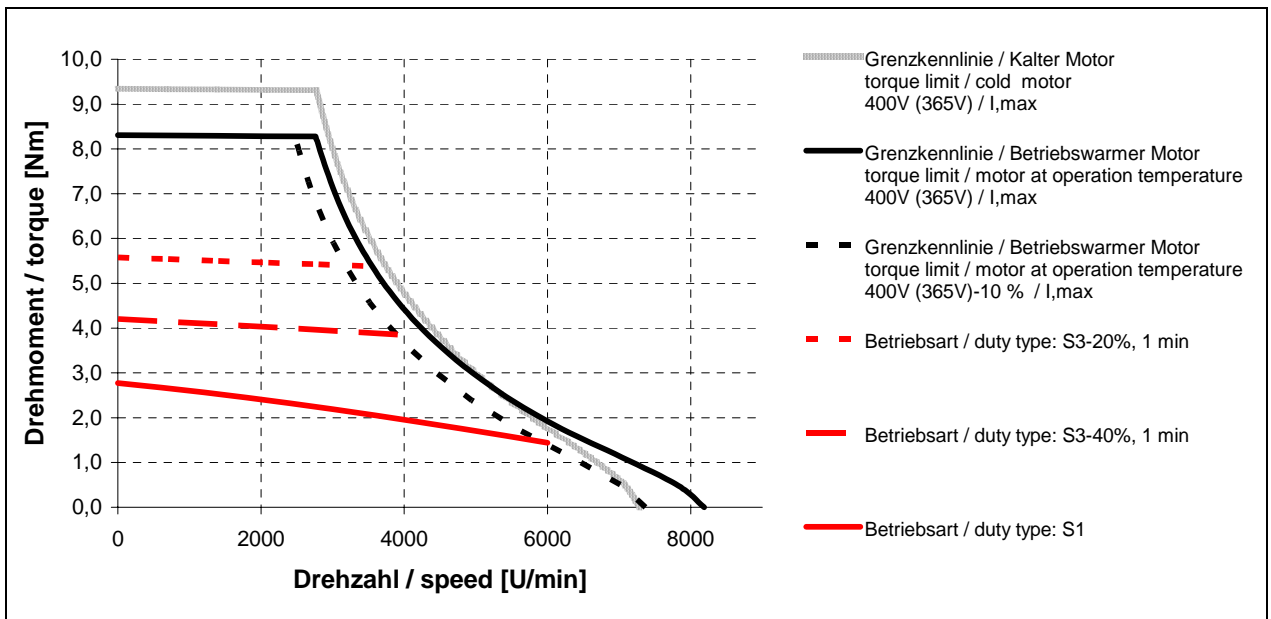

Headquarters

Baumüller Nürnberg GmbH

Ostendstraße 80-90, D-90482 Nürnberg
T: +49(0)911 5432-0, F: +49(0)911 5432-130
www.baumueller.com

Baumüller Anlagen-Systemtechnik GmbH & Co. KG

Ostendstraße 84, D-90482 Nürnberg
T: +49(0)911 54408-0, F: +49(0)911 54408-769
www.baumueller.com

Baumüller Reparaturwerk GmbH & Co. KG

Andernacher Straße 19, D-90411 Nürnberg
T: +49(0)911 9552-0, F: +49(0)911 9552-999
www.baumueller.com

Nürmont Installations GmbH & Co. KG

Am Keuper 14, D-90475 Nürnberg
T: +49(0)9128 9255-0, F: +49(0)9128 9255-333
www.nuermont.com

Subsidiaries

Australia

Baumüller Australia Pty. Ltd.
19 Baker Street, Botany NSW 2019, Sydney
T: +61 2 83350-100, F: +61 2 83350-169

Austria

Baumüller Austria Ges.mbh
Im Bäckerfeld 17, A-4060 Leonding
T: +43(0)732 674414-0, F: +43(0)732 674414-32

Brazil

NC Service Indústria e Comércio Ltda.
Av. Tamboré, 1217 Barueri-SP, BR-06460-000
T: +55(0)11 4195-0502, F: +55(0)11 4195-2479

China

Baumüller Automation Equipment Trading (Shanghai) Co. Ltd.
Cailun Rd. 88, Pudong Zhangjiang, 201203 Shanghai
T: +86(0)21 5855 1533, F: +86(0)21 5855 9487

China

Beijing Yanghai Automation Technology Co., Ltd.
Room 1008, No.7, Huaqing Business Building, Iluaqing Garden,
Wudaokou, Haidian District, 100083 Beijing
T: +86(0)10 8286 7980, F: +86(0)10 8286 7987

China

Sunary Automatic Technology Limited Company
3rd Floor No.476, Chunxiao Rd., Zhangjiang High-Tech Park
Pudong, Shanghai 201203
T: +86(0)21 5080 9898, F: +86(0)21 5308 7675

Czech Republic, Slovakia

VAE Prosys s.r.o.
Varsavska 9a, CZ-70900 Ostrava
T: +420-596 616 555, F: +420-596 616 777

Denmark

Robotek EL & Teknik A/S
Blokken 31, Postbox 30, DK-3460 Birkerød
T: +45 4484 7360, F: +45 4484 4177

Finland

Kontram Oy
Olarinluoma 12, P.O.Box 88, FI-02201 Espoo
T: +358 9 8866 4500, F: +358 9 8866 4799

France

Baumüller France S.à.r.l.
Zone de la Malnoue 39, Avenue de l'Europe, F-77184
Emerainville
T: +33 1 6461-6622, F: +33 1 6461-6006

France

Baumüller France S.à.r.l. (Strasbourg)
9 rue de la Durance, F-67100 Strasbourg
T: +33(0)3 88 40 12 51, F: +33(0)3 88 40 07 24

Germany - Darmstadt

Baumüller Nürnberg GmbH
Waldstraße 1, D-64347 Griesheim
T: +49(0)6155 8430-00, F: +49(0)6155 8430-20

Germany - Düsseldorf

Baumüller Nürnberg GmbH
Jacob-Kaiser-Straße 7, D-47877 Willich-Müncheide
T: +49(0)2154 487-0, F: +49(0)2154 487-59

Germany - Dresden

Baumüller Nürnberg GmbH
Nordstraße 57, D-01917 Kamenz
T: +49(0)3578 3406-0, F: +49(0)3578 3406-50

Germany - Freiberg

Nürmont Installations GmbH & Co. KG
Am Junger Löwe Schacht 11, D-09599 Freiberg
T: +49(0)3731 3084-0, F: +49(0)3731 3084-33

Germany - Hannover

Baumüller Nürnberg GmbH
Bohlenweg 10, D-30853 Langenhagen
T: +49(0)511 771 968-0, F: +49(0)511 771 968-77

Germany - München

Baumüller München GmbH
Meglingerstraße 58, D-81477 München
T: +49(0)89 748 898-10, F: +49(0)89 748 898-75

Germany - Nürnberg

Baumüller Nürnberg GmbH
Ostendstraße 80-90, D-90482 Nürnberg
T: +49(0)911 5432-501, F: +49(0)911 5432-510

Germany - Stuttgart

Baumüller Nürnberg GmbH
Hahnweidstraße 21, D-73230 Kirchheim/Teck
T: +49(0)7021 48557-10, F: +49(0)7021 48557-77

Germany - Stuttgart

Nürmont Installations GmbH & Co. KG
Im Ghai 12, D-73776 Altbach
T: +49(0)7153 92798-0, F: +49(0)7153 92798-99

Great Britain

Baumüller (UK) Ltd.
14 Redlands Centre, GB-Coulsdon, Surrey CR5 2HT
T: +44(0)208-763 2990, F: +44(0)208-763 2959

India

Baumüller KAT India Pvt. Ltd.
4th Floor, Commerce Avenue, Mahaganesh Colony, Paud Road,
IND-411038 Pune
T: +91 20 254596 82, F: +91 20 254596 84

Italy

Baumüller Italia s.r.l.
Viale Italia 12, I-20094 Corsico (Mi),
T: +39 02 45100-181, F: +39 02 45100-426

Korea

Bomac Systems
712 Yucheon Factophia, 196 Anyang-7 dong, Mananku,
Anyangsi, Kyungkido 430-017
T: +82 31 467-2030, F: +82 31 467-2033

Netherlands

Baumüller Benelux B.V.
Platinastraat 141, NL-2718 SR Zoetermeer
T: +31(0)79 3614-290, F: +31(0)79 3614-339

Poland

Mekelburger Polska
Ul. Kóscielna 39 F/3, PL-60537 Poznań,
T: +48(0)61 8481 520, F: +48(0)61 8481 520

Russia, Kazakhstan

Permanent K&M
Wolokolamskoye Chaussee 73, Office 517, Moscow, 125424
T: +7(095)9563867, F: +7(095)7803429

Slovenia

Baumüller Dravinja d.o.o.
Delavska cesta 10, SI-3210 Slovenske-Konjice
T: +386 3 75723-00, F: +386 3 75723-32/33

Spain

Baumüller Ibérica S.A.
C/Ausias Marc 13 1° 2a, E-08010 Barcelona
T: +34(0)93 342 69 26, F: +34(0)93 270 13 21

Sweden

Robotek EI & Teknik
Skårs Led 3, 40313 Göteborg
T: +46(0)31 703 71 90, F: +46(0)31 703 71 01

Switzerland

Baumüller Suisse S.A.
Rue des Usines 22, CH-2000 Neuchâtel
T: +41(0)32 7301-260, F: +41(0)32 7301-351

Switzerland

Baumüller Schweiz AG (Büro Ost)
Glärnischstrasse 46, CH-9500 Wil
T: +41(0)71 929 46-66, F: +41(0)71 929 46-67

Turkey

Baumüller Motor Kontrol Sistem SAN. VE TIC. LTD. STI
Colak Ismail Sok. No: 31/1, TR-81070 Istanbul-Suadiye
T: +90(0)216 372-2485, F: +90(0)216 372-7570

USA

Baumüller Inc.
117 West Dudley Town Road, USA-Bloomfield, CT 06002
T: +1 860-243-0232, F: +1 860-286-3080

USA

Baumüller Inc.
1512 East Algonquin Road, USA-Arlington Heights, IL 60005
T: +1 847-956-7392, F: +1 847-956-7925

USA

Baumüller-Nuermont Corp.
1512 East Algonquin Road, USA-Arlington Heights, IL 60005
T: +1 847-956-7392, F: +1 847-956-7925

USA

Baumüller-Nuermont Corp.
2650 Pleasantdale Road, Suite 15, USA-Doraville, GA 30340
T: +1 678-291-0535, F: +1 678-291-0537

Venezuela, Colombia, Ecuador

Nimbus International C.A.
C.C. Parque Tuy, Local P-18, YV-Ocumare del Tuy, 1209
T: +58 239 25 1347, F: +58 23

be in motion

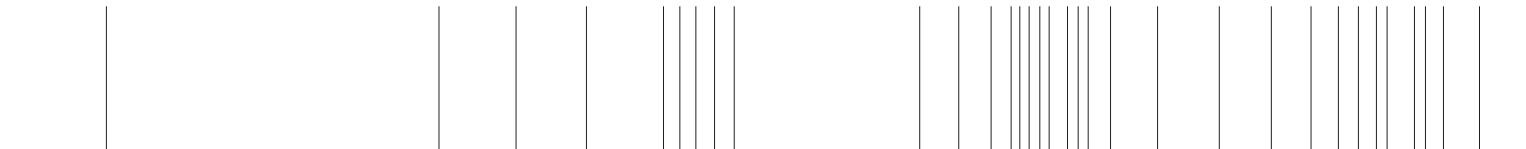

Responsible for content: Baumüller Nürnberg GmbH Ostendstraße 80-90 90482 Nürnberg T: +49(0)911 54 32-0 F: +49(0)911 54 32-130 www.baumueller.com
Baumüller Anlagen-Systemtechnik GmbH & Co. KG Ostendstraße 84 90482 Nürnberg T: +49(0)911 544 08-0 F: +49(0)911 544 08-769
Baumüller Reparaturwerk GmbH & Co. KG Andernacher Str. 19 90411 Nürnberg T: +49(0)911 95 52-0 F: +49(0)911 95 52-999

All data/information and particulars given in this brochure is non-binding customer information, subject to constant further development and continuously updated by our permanent alteration service. Please note that all particulars/figures/information is current data at the date of printing. These particulars are not legally binding for the purpose of measurement, calculation or cost accounting. Prior to using any of the information contained in this brochure as a basis for your own calculations and/or applications, please inform yourself about whether the information you have at your disposal is up to date. Therefore, no liability is assumed for the correctness of the information.

3.190.e.05/06.10B
05/06